

TRF 419 WORLD CHAMPION TEAM

TAMIYA RACING FACTORY

SETTING SHEET

Name _____ Date _____ Air temp. _____ Humidity _____

Track _____ Track condition _____ Track temp. _____

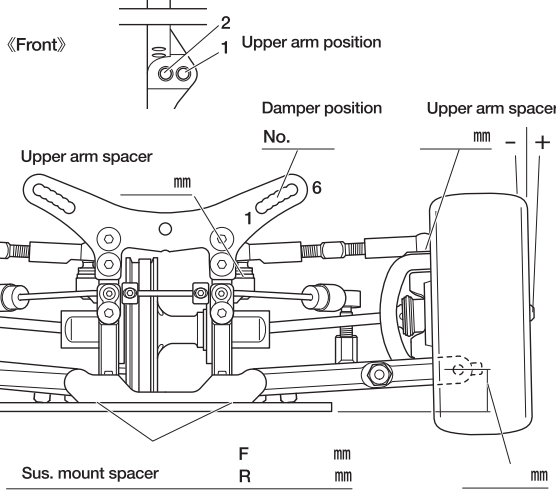

Front axle _____ °

Camber angle _____ °

Ground clearance _____ mm

Rebound stroke _____ mm

Stabilizer _____

Wheel spacer _____ mm

Front drive _____

Differential oil # _____ %

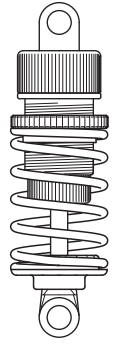

Damper type _____

Piston _____ hole(s)

Oil _____ #

Spring _____

Memo _____

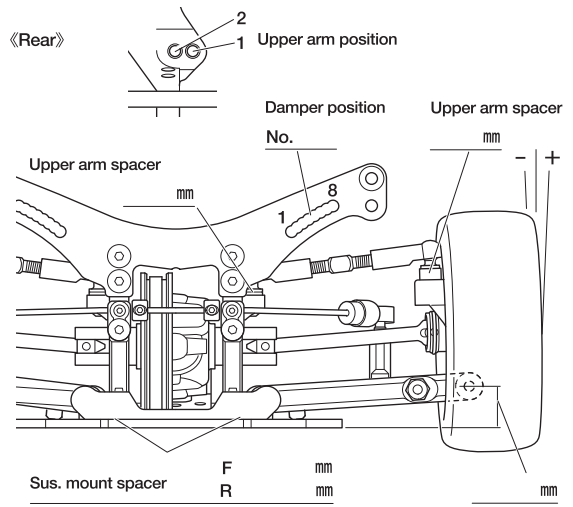

Rear upright 416 / 418

Camber angle _____ °

Ground clearance _____ mm

Rebound stroke _____ mm

Stabilizer _____

Wheel spacer _____ mm

Rear drive _____

Differential oil _____

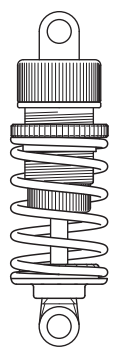

Damper type _____

Piston _____ hole(s)

Oil _____ #

Spring _____

Memo _____

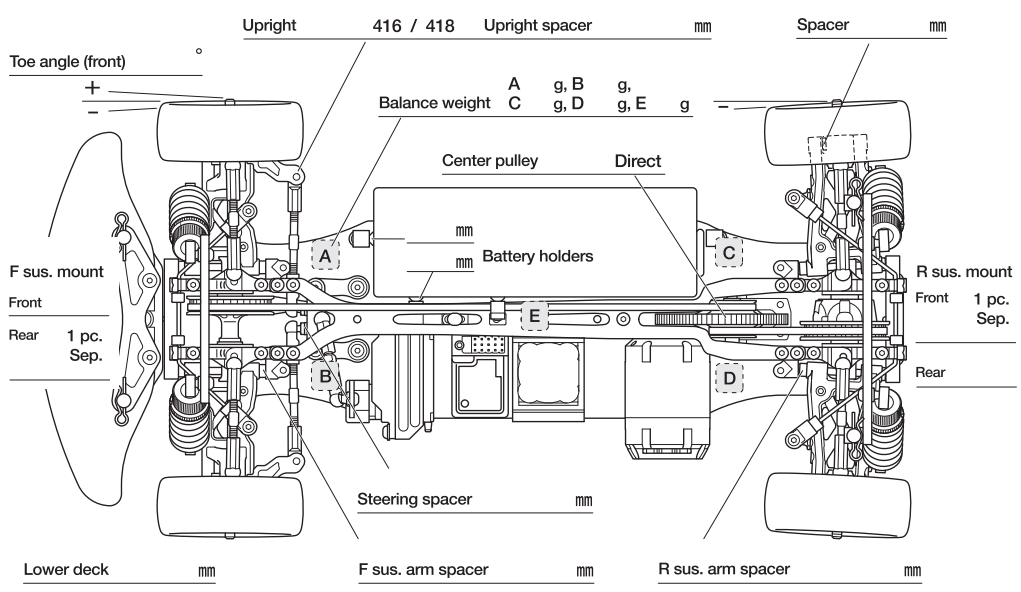

Motor _____

Spur _____ Pinion _____ Pitch _____

Battery _____ / _____ g

Body _____

Wing _____

Tire _____

Wheel _____

Tire insert _____

Best lap _____