

# TRF 419 WORLD CHAMPION TEAM

TAMIYA RACING FACTORY

## SETTING SHEET

Name **Ed Clark** Date **2nd&3rd May 15** Air temp. **18** Humidity **90**  
 Track **Whalan - NSW States 2015** Track condition **Low - Med grip** Track temp. **16**

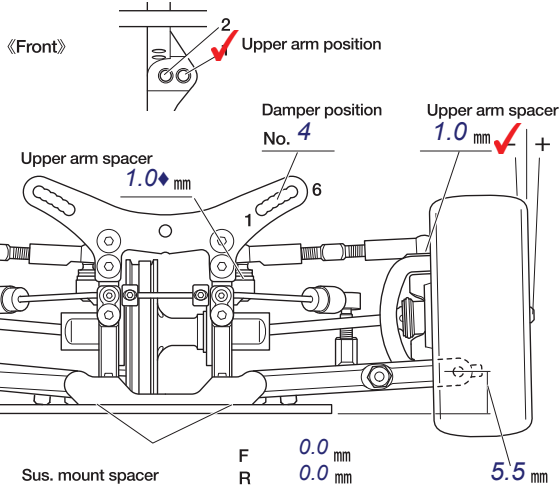

Front axle	4°
Camber angle	-1.5°
Ground clearance	5.4 mm
Rebound stroke	3 mm
Stabilizer	Black (1.3mm)
Wheel spacer	0.5 mm
Front drive	Spool
Differential oil	# %

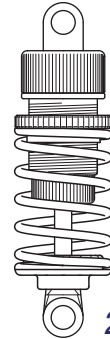

Damper type	TRF419
Piston	3 x 1.1mm hole(s)
Oil	MuchMore 400 #
Spring	Schumacher Green

2x Blue Comp. O-rings in bottom of shocks F&R  
 Droop on 10mm blocks and gauge to arm under pin

Memo

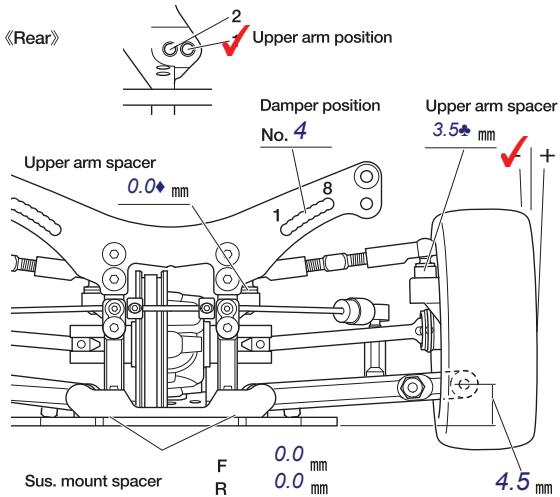

Rear upright	416 / 8
Camber angle	-2.0°
Ground clearance	5.6 mm
Rebound stroke	3 mm
Stabilizer	Black (1.2mm)
Wheel spacer	0.5 mm
Rear drive	Gear Diff
Differential oil	MuchMore 5000



Damper type	TRF419
Piston	3 x 1.1mm hole(s)
Oil	MuchMore 400 #
Spring	Schumacher Green

Two screws in motor mount  
 Roll bar in middle arm hole  
 H5 ballstud used  
 Standard ball stud used

Memo

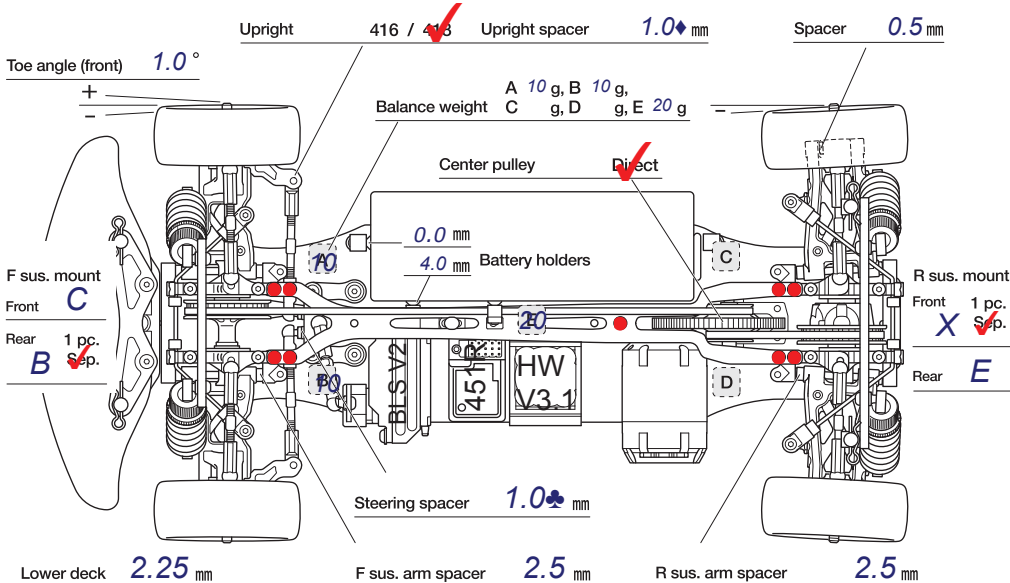

Motor	Hobbywing V10 4.5t				
Spur	86 <sub>T</sub>	Pinion	22 <sub>T</sub>	Pitch	48
Battery	ProAmps 6000				300 g
Body	LTC-R lwt				
Wing	MR33				
Tire	Volante 36				
Wheel	Volante Red				
Tire insert	Volante				
Best lap					