

TRF 419 WORLD CHAMPION TEAM

TAMIYA RACING FACTORY

SETTING SHEET

Name **Ed Clark** Date **17Mar2015** Air temp. **18°C** Humidity **45%**
 Track **SMA** Track condition **Good - Low - Med** Track temp. **22°C**

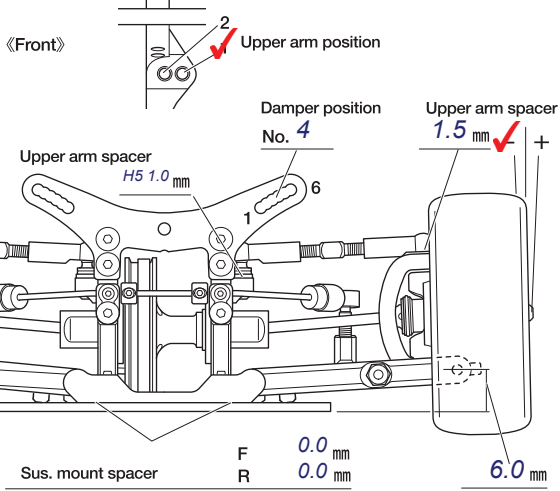

Front axle	4°
Camber angle	-1.5°
Ground clearance	5.2 mm
Rebound stroke	3 mm
Stabilizer	Black (1.3mm)
Wheel spacer	0.5 mm
Front drive	Spool
Differential oil	# %



Damper type	TRF419
Piston	3 x 1.1mm hole(s)
Oil	MuchMore 450 #
Spring	Schumacher Green

2x Blue Comp. O-rings in bottom of shocks F&R
 Droop on 10mm blocks and gauge to arm under pin

Memo

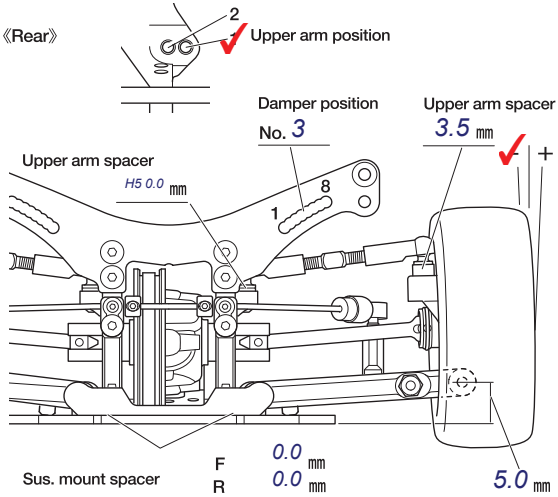

Rear upright	416 / 8
Camber angle	-2.0°
Ground clearance	5.4 mm
Rebound stroke	3 mm
Stabilizer	Black (1.2mm)
Wheel spacer	0.5 mm
Rear drive	Gear Diff
Differential oil	MuchMore 3000

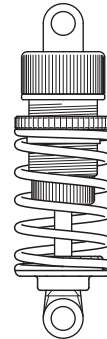

Damper type	TRF419
Piston	3 x 1.1mm hole(s)
Oil	MuchMore 450 #
Spring	Schumacher Green

Four screws in motor mount
 Roll bar in middle arm hole

Memo

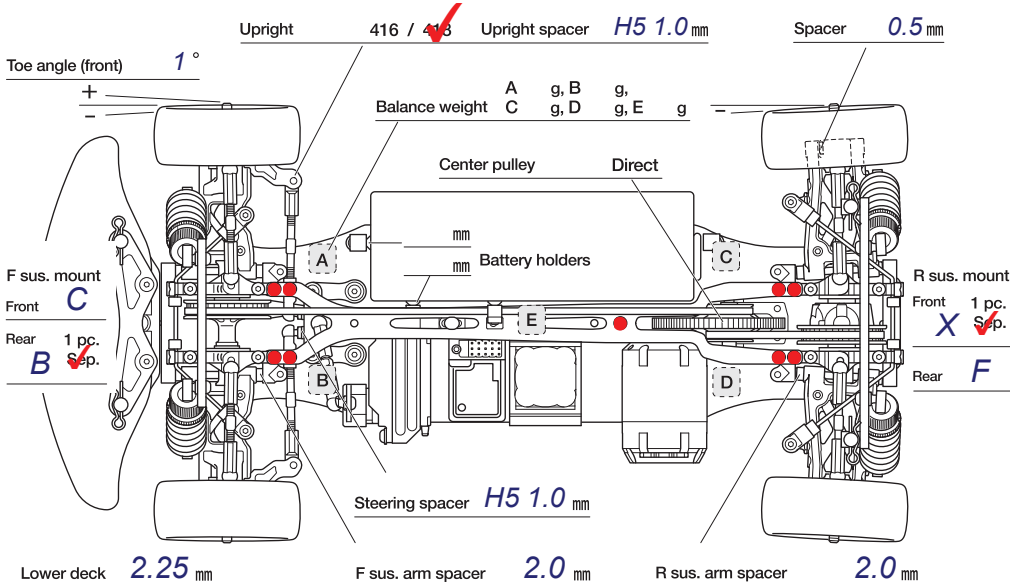

Motor	Hobbywing V10 4.5t
Spur	86 _T Pinion 20 _T Pitch 48
Battery	ProAmps 6000 , 300 g
Body	LTC-R lwt
Wing	MR33
Tire	Rush 36X
Wheel	MuchMore
Tire insert	MuchMore Yellow
Best lap	